

PIPE TEE CROSS 2010 - 00010002- 000

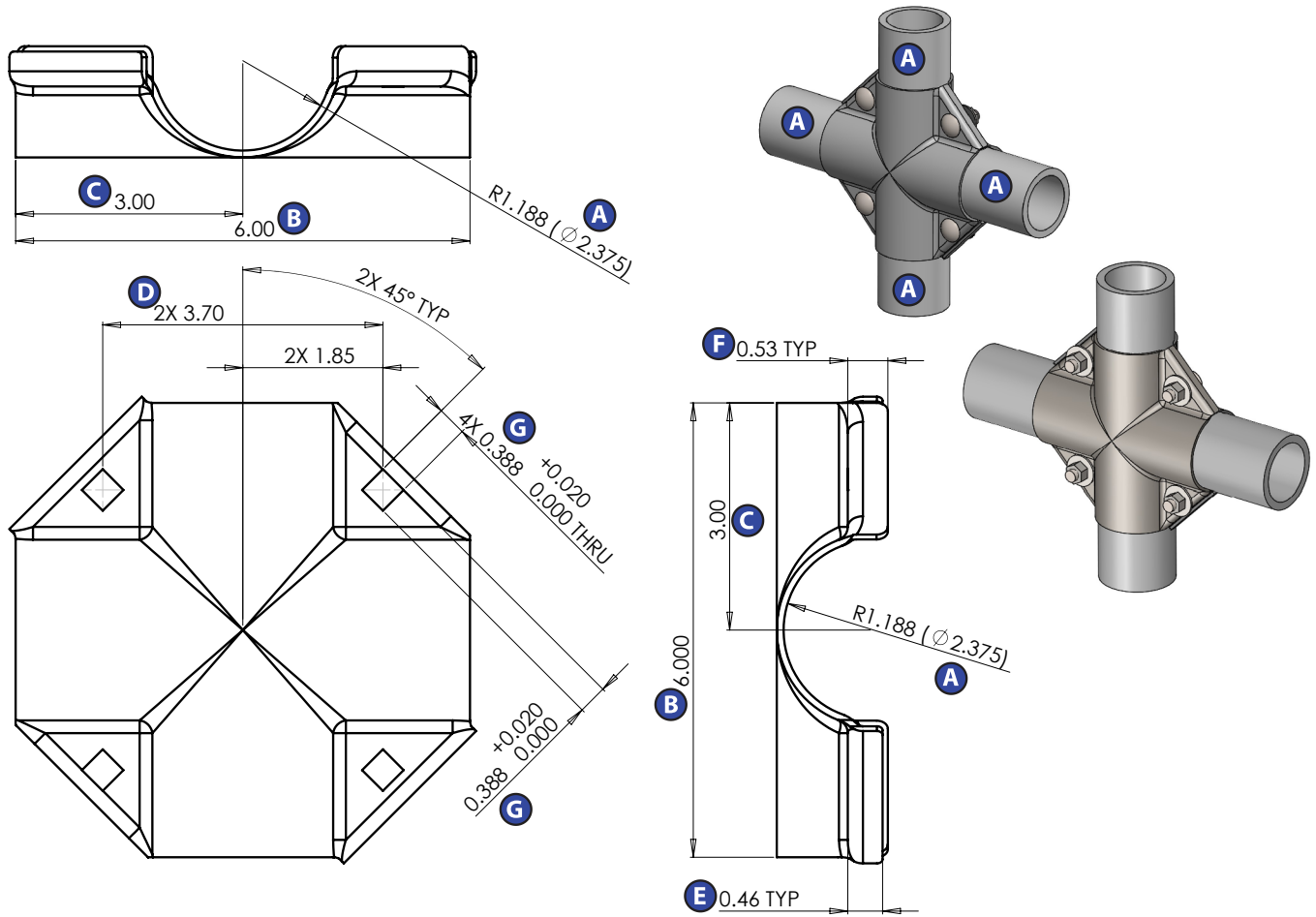

PIPE SIZE A	B	C	D	E	F	G	MATL ³ THICK	MATL ³	FINISH ¹	Wt. (Lbs)	ORDERING PART NUMBER ²
2.375	6.00	3.00	3.70	.46	.53	.388	.090 (13 GA)	STEEL	PLAIN NO FINISH	1.01/half 2.02/connector	2010-00110002-001
2.375	6.00	3.00	3.70	.46	.53	.388	.090 (13 GA)	STEEL	HOT DIPPED GALVANIZED	1.01/half 2.02/connector	2010-00110002-002
2.875	7.25	3.63	4.40	.52	.53	.388	.105 (12 GA)	STEEL	PLAIN NO FINISH	1.72/half 3.44/connector	2010-00210002-001
2.875	7.25	3.63	4.40	.52	.53	.388	.105 (12 GA)	STEEL	HOT DIPPED GALVANIZED	1.72/half 3.44/connector	2010-00210002-002

1. FINIISH:

Available in HDG (hot dipped galvanized) and available with no finish. Galvanized finish per ASTM A153 and ASTM A123.

2. PART NUMBER; 2010-00110002-001:

2010 signifies assembly of connector/s and corresponding hardware (bolts, washers and nuts).

-001 signifies nominal 2" pipe diameter (OD 2.375"), -002 signifies nominal 2 1/2" pipe diameter (OD 2.875")

10002 signifies a unique part number, PIPE TEE CROSS.

-001 signifies the part finish, PLAIN, NO FINISH, -002 signifies the part finish, HDG (hot dipped galvanized).

3. ORDERING: The ordering part number consists of 2 - Pipe Tee Cross halves with 4 - Grade 5 bolts, washers and nuts.

4. MATERIAL:

1008 CR Steel.

5. INSTALLATION:

For proper installation use 4 - 3/8 x 1 1/4 - 16 UNC minimum SAE Grade 5 steel bolts, washers and nuts or equivalent. Bolts can be either carriage or hex head type. Torque bolts evenly to 25 ft.-lbs. Avoid over tightening and use the supplied bolts, nuts and washers or equivalent.

6. DIMENSIONS: All dimensions are in inches.